

# **Inductive Balancer for Lithium Battery**

## **Operation and Maintenance Manual**

**Heltec Energy**

## Content

1. Introduction .....	1
2. Technical Specifications .....	2
3. Installation and Assembly .....	3
3.1 Connection Description .....	3
3.2 Wiring Diagram .....	4
4. Precaution for Use .....	10

## 1. Introduction

The lithium battery active balancer is tailor-made for the charging and discharging of large-capacity series-parallel battery packs, and it has the whole set of overall non-differential equalization. The circuit board is sprayed with three-proof paint, which has excellent insulation, moisture-proof, leakage-proof, shock-proof, dust-proof, anti-corrosion, anti-aging, corona resistance and other properties. It can effectively protect the circuit and improve the safety and reliability of the product. This product is suitable for ternary lithium and lithium iron phosphate, the maximum balanced voltage difference is 0.03V, and the maximum balanced current is 1.2A. When the voltage difference is 0.1V, the current is about 0.5-0.7A (actually related to the capacity and internal resistance of the battery). Product appearance shown in Figure 1.

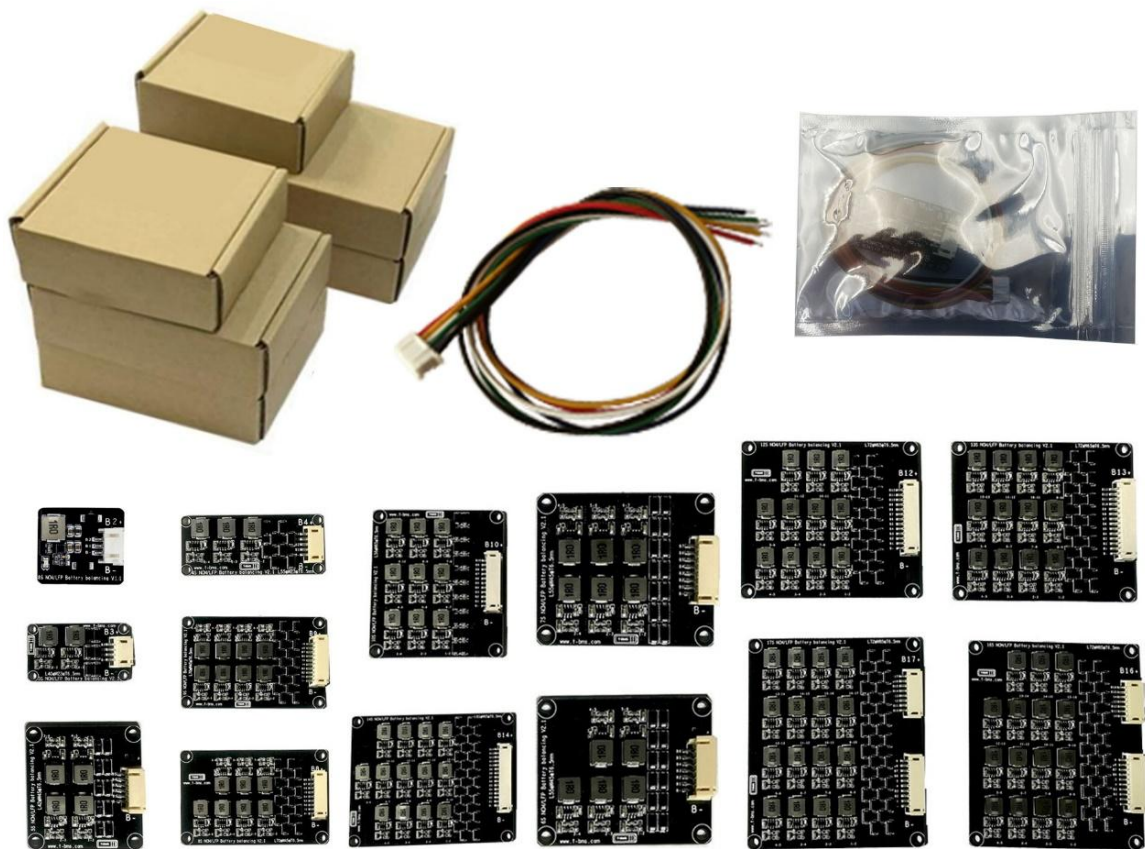

Figure 1. Inductive Balancer

## 2. Technical Specifications

This module is for adjacent voltage difference equalization. When the voltage difference between adjacent batteries reaches above 0.1V, the chip internally triggers the balancing operation until the voltage difference between adjacent batteries is within 0.03V and stops working. It is used in battery packs where adjacent voltage differences exist when charging and discharging. When the equalization work is triggered, the battery pack voltage error will also be pulled back to a more ideal value, reducing battery maintenance costs. Table 1 Main technical indicators of balancing board.

Table 1. Main Technical Indicators of Inductive Balancer

Technical Index	Product Model														
Applicable Battery Strings	2S	3S	4S	5S	6S	7S	8S	9S	10S	11S	12S	13S	14S	16S	17S
Applicable Battery Type	NCM/LFP Ternary Lithium/Lithium Iron														
Working Range of Single Voltage	NCM/LFP version: 3.0V-4.2V														
Voltage Equalization Accuracy	Adjacent voltage difference 30mV (typical)														
Balanced Mode	Detect the nearby battery voltage difference. When it's greater than 0.1V, the equalization will be triggered. When it's less than 0.3V, it will stop working.														
Equalizing Current	When the voltage difference is 0.1V, the equalizing current will be 0.5A. When the voltage difference is 0.2V, the equalizing current will achieve the max value of 1.2A.														
Sleep Voltage	When the adjacent voltage is less than 0.03V, it will enter dormant state.														
Static Working Current	0.01mA														
Product Size (mm)	24* 20* 6.5	40* 23* 6.5	55* 23* 6.5	42* 45* 6.5	55* 45* 6.5	55* 45* 6.5	70* 45* 6.5	70* 45* 6.5	56* 65* 6.5	77* 40* 6.5	72* 65* 6.5	72* 65* 6.5	81* 65* 6.5	72* 85* 6.5	72* 85* 6.5
Working Environment Temperature	-20°C~60°C														
External Power	No need for external power supply, relying on the internal energy transfer of the battery to achieve the adjacent equalization.														

### 3. Installation and Assembly

#### 3.1 Connection Description

The connection position of the equalization board is shown in figure 2, and its definition is shown in table 2.

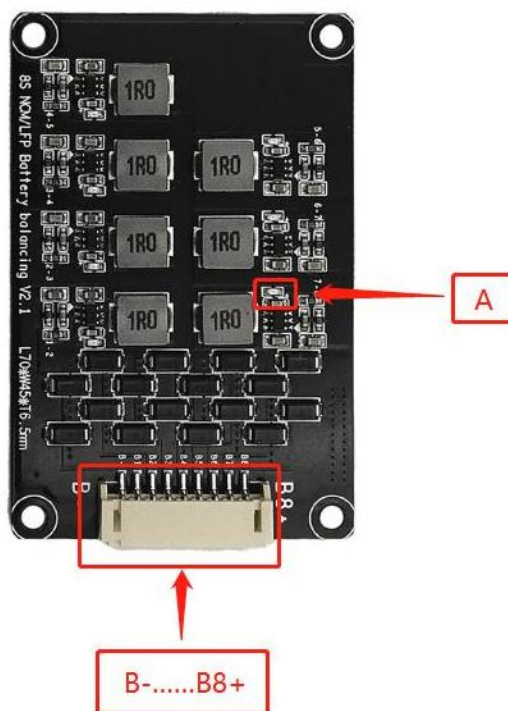

Figure 2. 8S 1.2A (SKU0794) - Connection Diagram

Table 2. Connection Definition

Connector	8S 1.2A (SKU0794)	
	Name	Definition
A	LED Indicator Light	Always on: Balancing/off; Unbalanced/Flickering: Circuit fault.
B- ~ B8+	B-	The negative pole of the 1 <sup>st</sup> string
	B1+	The positive pole of the 1 <sup>st</sup> string
	B2+	The positive pole of the 2 <sup>nd</sup> string
	B3+	The positive pole of the 3 <sup>rd</sup> string

	B4+	The positive pole of the 4 <sup>th</sup> string
	B5+	The positive pole of the 5 <sup>th</sup> string
	B6+	The positive pole of the 6 <sup>th</sup> string
	B7+	The positive pole of the 7 <sup>th</sup> string
	B8+	The positive pole of the 8 <sup>th</sup> string

Note: (Flex cable plugs with more than 13 strings need to be inserted diagonally. Contact the B- pin first and insert it diagonally upward, otherwise the board may be burned!)

### 3.2 Wiring Diagram

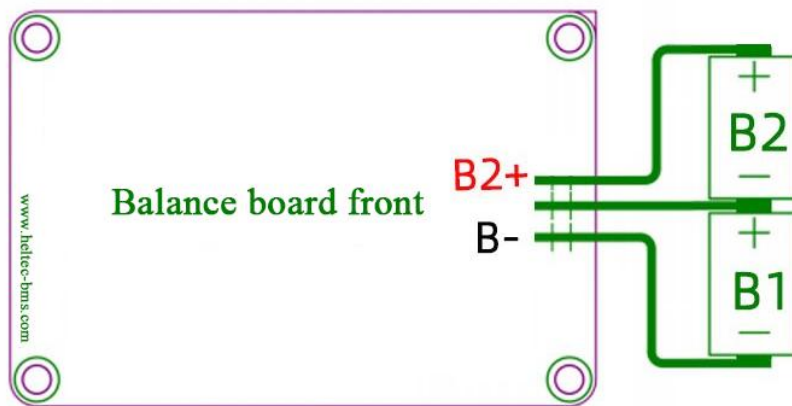

Figure 3. 2S Wiring Diagram

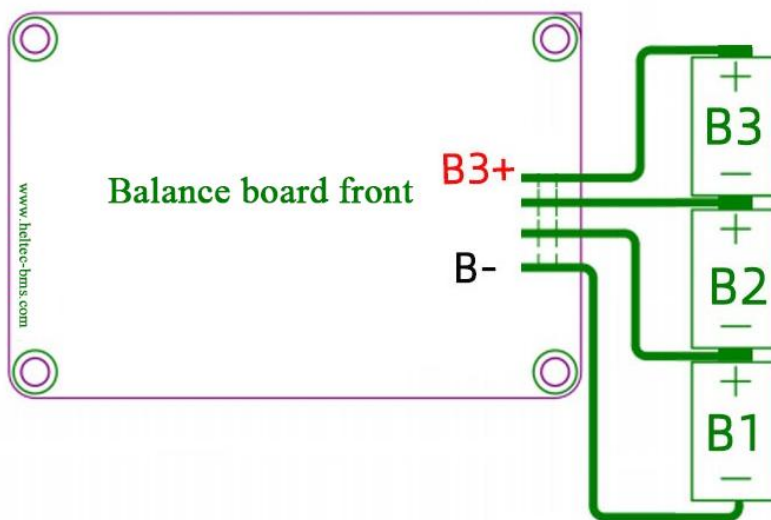

Figure 4. 3S Wiring Diagram

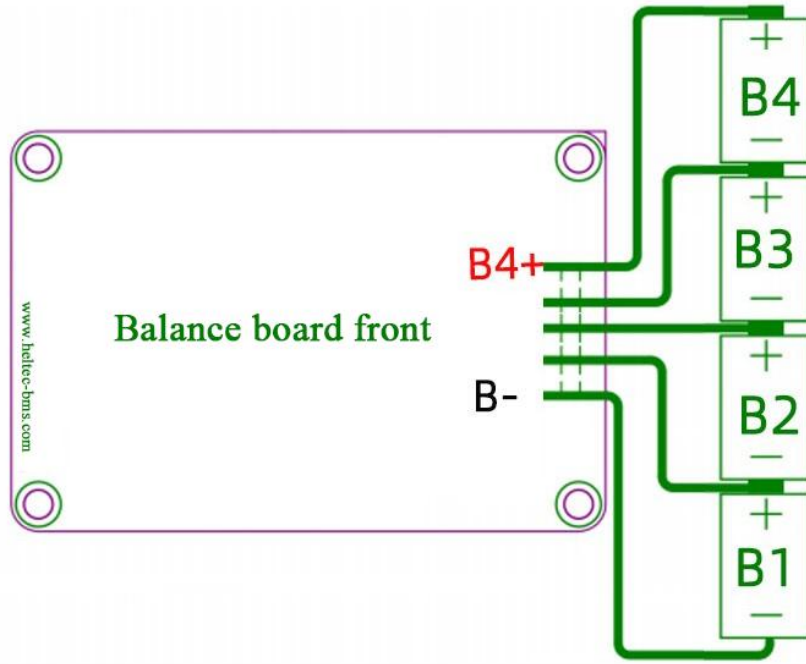

Figure 5. 4S Wiring Diagram

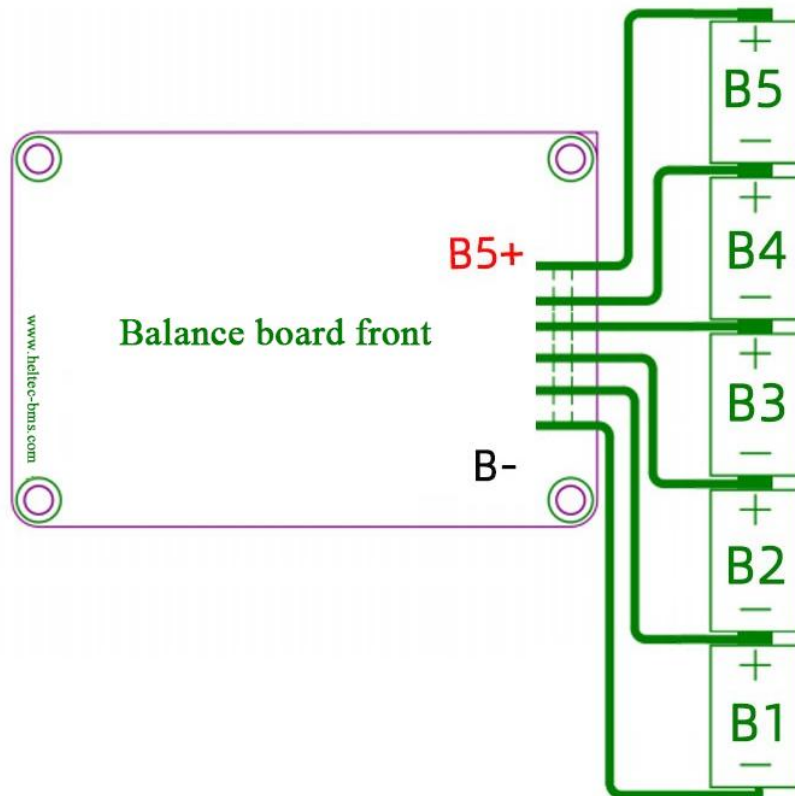
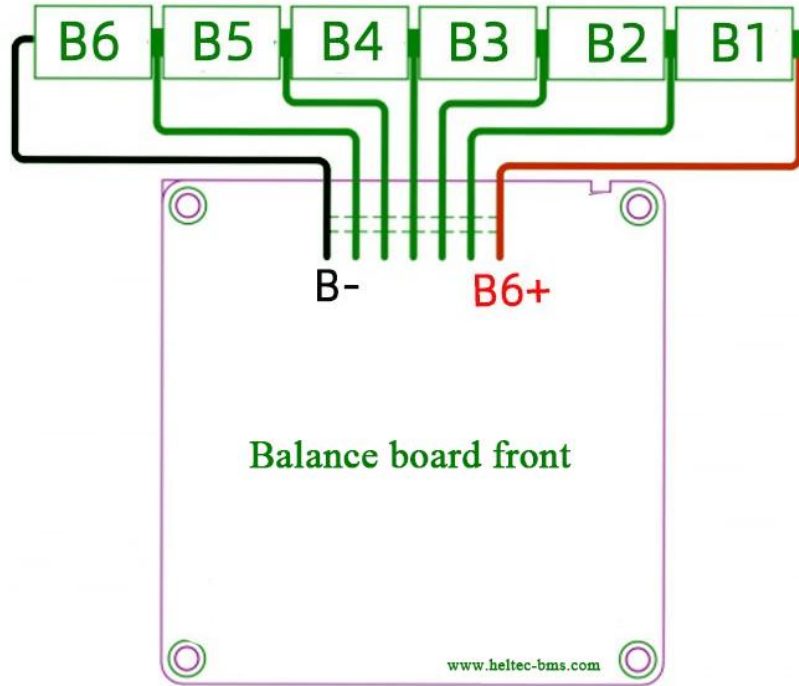

Figure 6. 5S Wiring Diagram



1

Figure 7. 6S Wiring Diagram

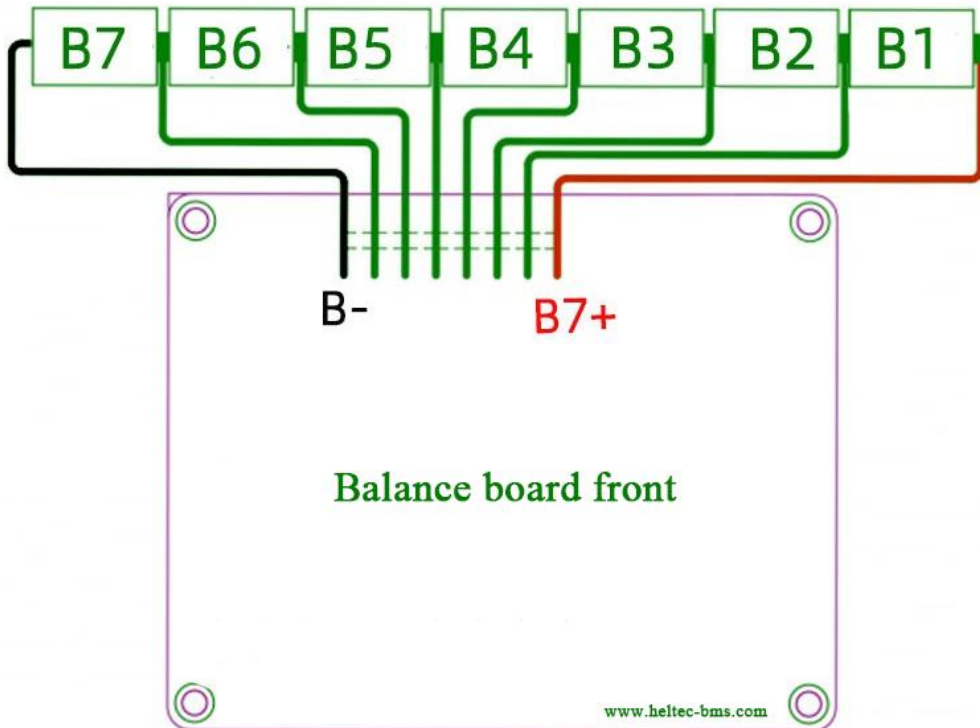

Figure 8. 7S Wiring Diagram



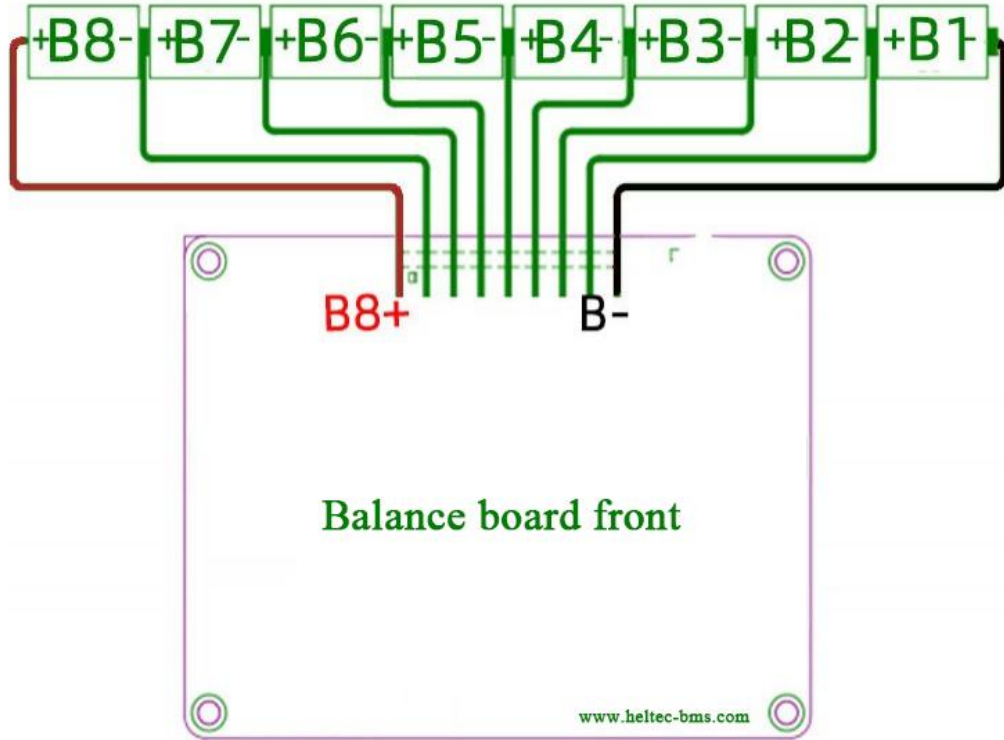

Figure 9. 8S Wiring Diagram

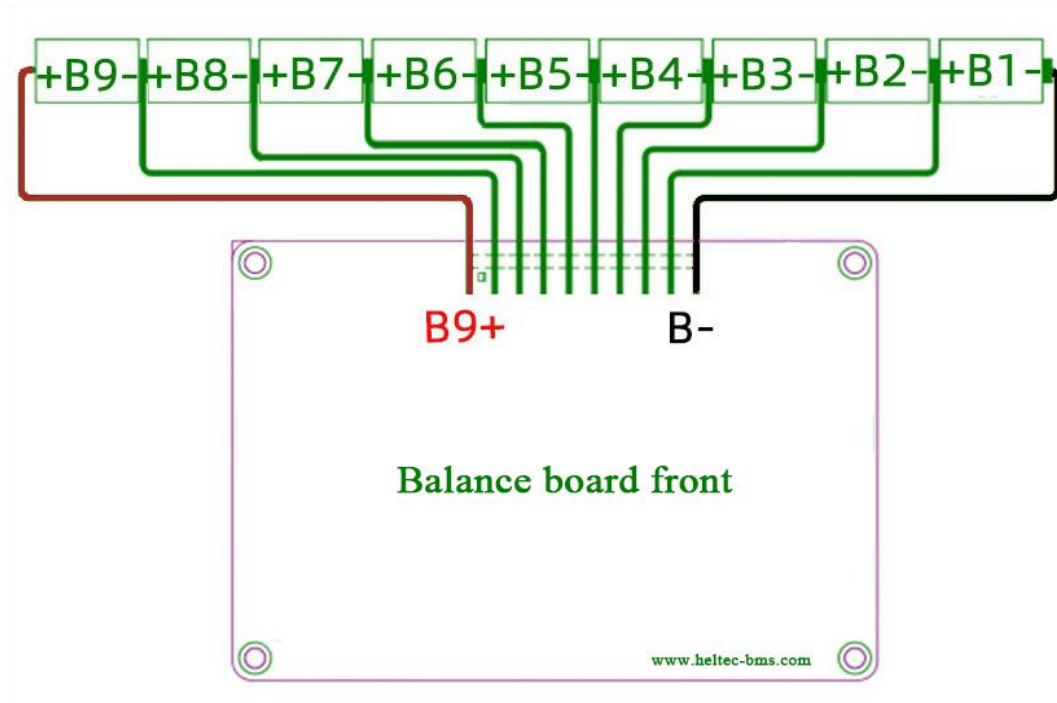

Figure 10. 9S Wiring Diagram

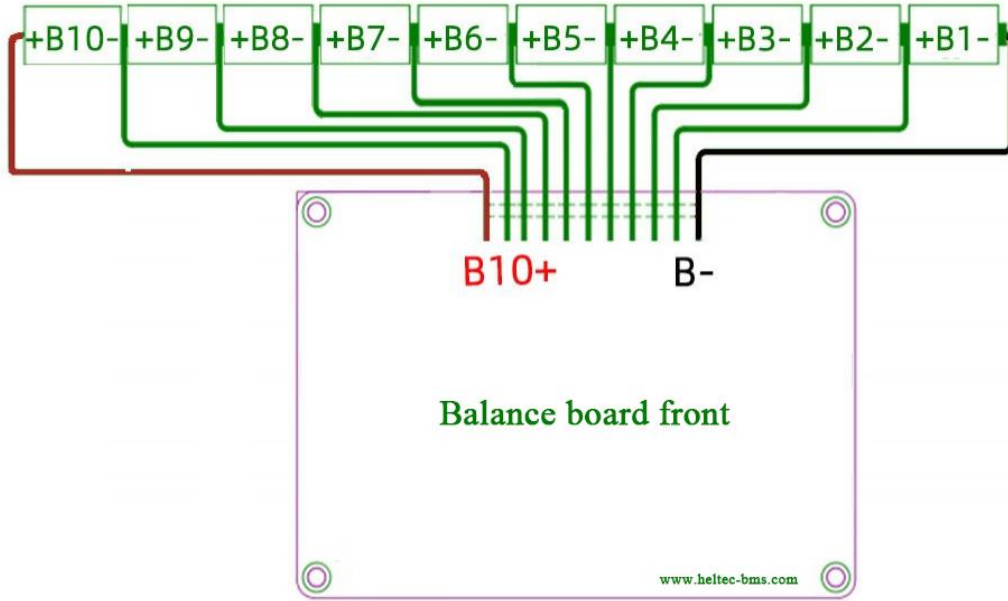

Figure 11. 10S Wiring Diagram

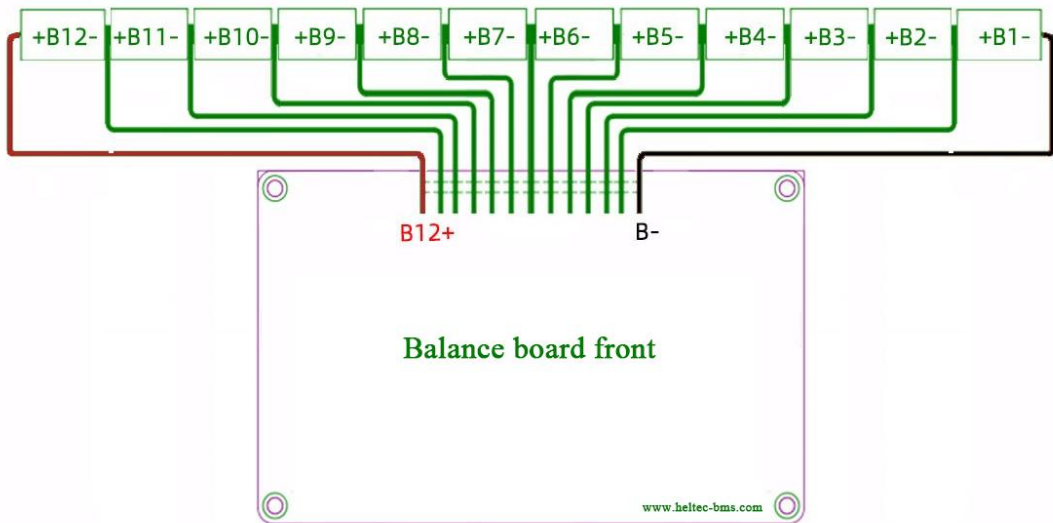

Figure 12. 12S Wiring Diagram

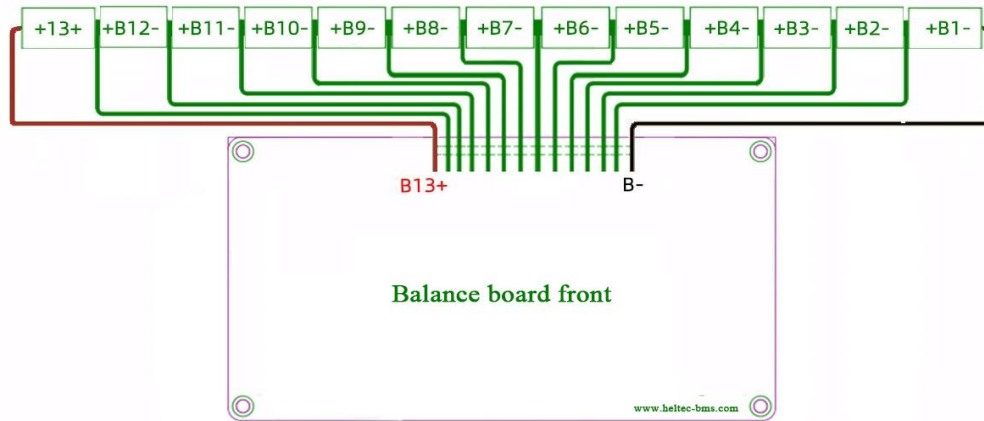

Figure 13. 13S Wiring Diagram

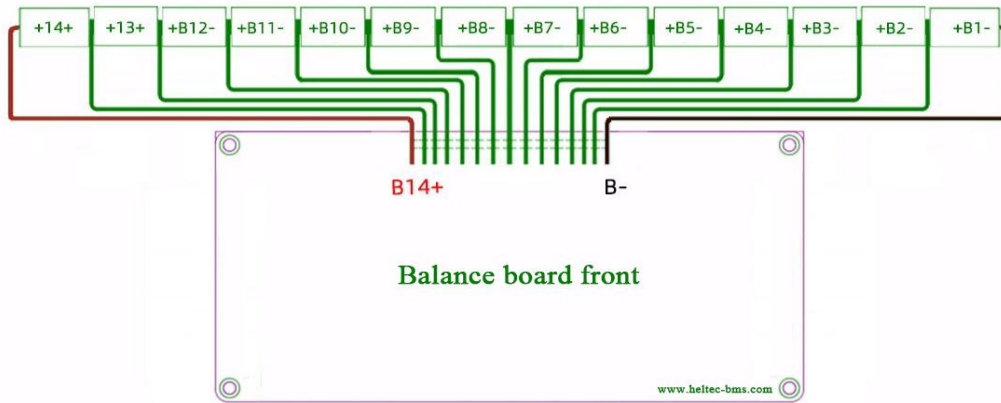

Figure 14. 14S Wiring Diagram

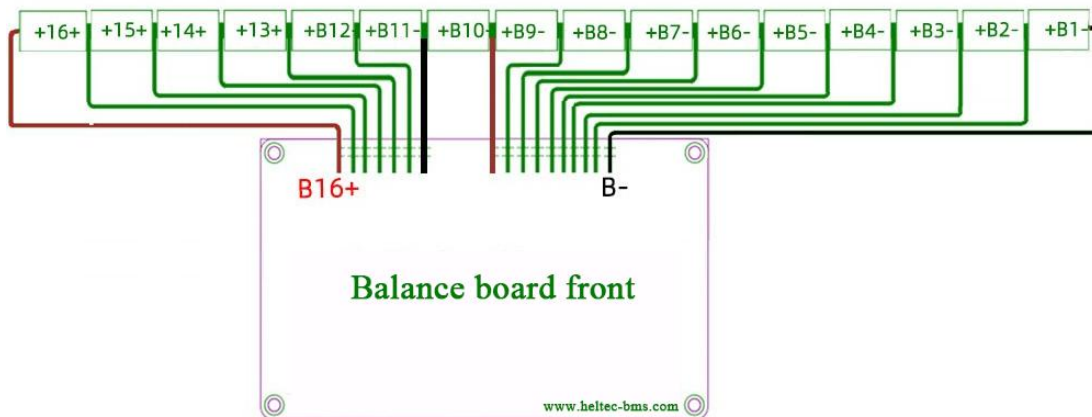

Figure 15. 16S Wiring Diagram

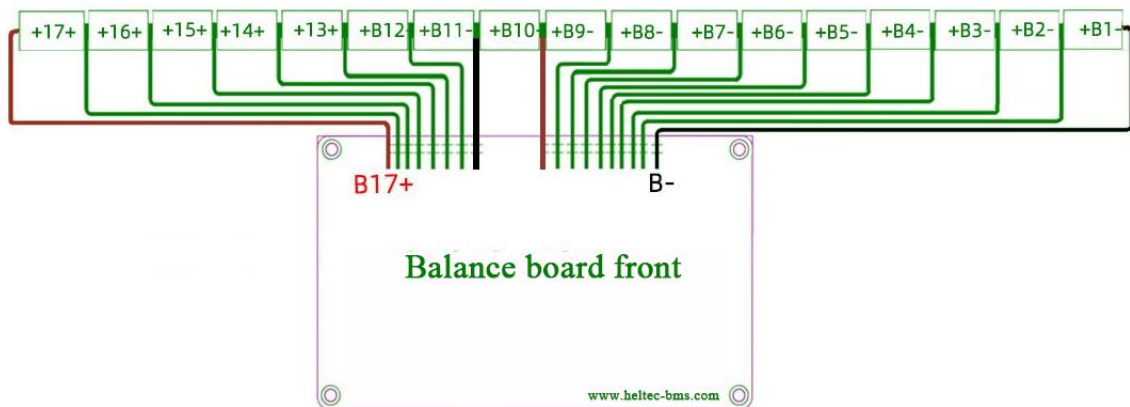

Figure 16. 17S Wiring Diagram

#### 4. Precaution for Use

- This board works on the principle of adjacent balancing and cannot be used as a maintenance tool. To connect to the battery, it must be used with lithium battery protection. The voltage difference generated by charging and discharging triggers the balancing board to achieve energy transfer balancing.
- Be sure to follow the design parameters and usage conditions during use, and do not use it in violation of the parameters in this specification, otherwise it will easily damage the protective plate and then damage the battery pack.
- It is necessary to prevent static electricity during use. When testing, installing, and touching the protective board, corresponding static discharge measures must be taken.
- Be careful not to touch the components on the circuit board with the lead wire, electric soldering iron, tin slag, etc. during use, otherwise the balance board may be damaged.
- If there is any abnormality during use, please stop using it immediately, send it back to the original factory or ask professional maintenance personnel to repair it.
- This balancing board has undergone a large number of reliability tests. The reliability is much higher than the general balancing boards on the market. The process of the battery core must also be guaranteed at the same time to reduce the

occurrence of combustion as much as possible.

**\* Safety Precautions:**

Our company is committed to the improvement of quality and reliability, but generally speaking, electrical products will have a certain probability of failure. The durability will be different due to the different environmental conditions of use; the lengthy design is adopted during use to avoid abnormal heat, smoke, and even personal accidents, fire accidents, and social damages caused by overloading.